

Composites bring efficiency, safety, and flexibility

LICO



Composite materials are an excellent choice for manufacturing dashboards, cockpit components, and interior panels for mobile equipment.



Composites make it possible to create a safe cockpit environment and improve the accessibility of controls through greater design freedom. A pre-assembled modular composite dashboard can speed up equipment assembly and shorten lead times.



The use of composites in interior structures can help increase payload capacity or improve vehicle mobility. At the same time, it expands the possibilities for selecting controls and accessories. Pre-installation can further accelerate the final assembly of the vehicle or machine.



This solution is especially well suited for military vehicles, marine vessels, and rail transport vehicles.



FRONT VIEW



TOP VIEW



SIDE VIEW (RIGHT)

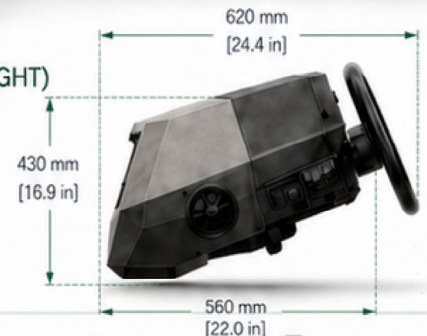

Interested?
Get in touch.



LICO Oy, Hitsaajankatu 7,
61300 KURIKKA



Arto Pitkämä CEO
+358 400 917 282
arto.pitkamo@lico.fi



Jari-Pekka Tiesmäki CSO
+358 40 510 3001
jari-pekka.tiesmaki@lico.fi